

User's Manual

LK-330E

Label and Mark Printer



LABEL & MARK INDUSTRIES COMPANY

Contents

Chapter I	Foreword	3
Chapter II	Preparation	8
2.1	Configuration of the Main Unit	8
2.1.1	Basic configuration	8
2.1.2	List of consumables provided	9
2.2	Nomenclature and Functions	11
2.2.1	Main unit	11
2.2.2	LCD display description	11
2.2.3	Keyboard	13
2.3	Installation	15
2.3.1	Installation and removal of Ribbon	15
2.3.2	Installation and removal of printing material cassette	17
2.3.3	Installation of sleeve tube guide	18
2.3.4	Installation of sleeve tube	19
2.3.5	Removal of sleeve tube guide	20
2.3.6	Connection of AC power adaptor	20
2.3.7	Connection of data cable	20
2.3.8	Power switch	21
Chapter III	Basic Operation	22
3.1	Power-on	22
3.1	Selection of Printing Material	22
3.2	Selection of Printing Material Specifications	22
3.2.1	Selection of sleeve tube specifications	22
3.2.2	Selection of label specifications	23
3.2.3	Selection of heat shrink tube specifications	23
3.2.4	Selection of Font Size	24
3.2.5	Change Character Size	24
3.3	Enter Print Contents	25
3.4	Insertion	26
3.5	Change of Contents	27
Chapter IV	Function Keys	28
4.1	Notes to Function Keys	28
4.2	Instructions for Function Keys	29
4.2.1	Medium	29
4.2.2	Length	30
4.2.3	[A / >] Orientation	31
4.2.4	Font size	32
4.2.5	Spacing	33
4.2.6	Density	33
4.2.7	Frame	34
4.2.8	Number	35

4.2.9 Repeat.....	37
4.2.10 Alignment.....	38
4.2.11 Double Line.....	40
4.2.12 PC Conn.....	40
4.2.13 File.....	41
4.2.14 Delete all.....	43
4.2.15 Symbol.....	44
4.2.16 Delete.....	44
4.2.17 Cancel.....	45
4.2.18 Superscript.....	45
4.2.19 Subscript.....	45
4.2.20 Text head.....	46
4.2.21 Text end.....	46
4.2.22 Cutting set.....	46
4.2.22 Cut depth.....	46
4.2.23 Print Scope.....	48
4.2.24 Print.....	48
4.2.25 Capital.....	48
4.2.26 Language.....	49
4.2.27 Back Off.....	49
4.2.28 Backspace.....	49
4.2.29 [Shift].....	50
4.2.30 Revise.....	50
4.2.31 Create a new page.....	53
4.2.32 Display brightness adjustment.....	53
4.2.33 Key combination.....	53
Chapter V Specifications Description.....	54
Chapter VI Others.....	55
6.1 Specifications of Original Consumables.....	55
6.2 Simple Trouble-shooting.....	56
6.2 Warranty Card.....	57

Chapter I Foreword

Welcome to use LK-330E label & mark printer! This manual describes the features of LK-330E and the points of attention during operating and using it. Please study this manual to have an adequate understanding of LK-330E features before you use this machine so as to take a better advantage of it. After reading it, keep this manual properly for future reference.

[Statement]

1. The “**L-MARK**” are the registered trade marks of Label & Mark Industries Company.
2. The contents of this manual shall not be altered without prior consent. The Company reserves the right to bring changes to the products concerning technologies, parts and components, software and hardware. For more information about the products, please contact **L-MARK** or the sale agents.
3. Without the prior written approval by **L-MARK**, no contents of this manual shall be copied or transmitted in any form or by any means.
4. The Company is not to be held responsible for any consequences that may arise from any operations not conforming to the instructions contained in this manual.
5. Other signs and trade marks referenced in this manual are owned by their respective owners.
6. This manual is subject to change without prior notice.
7. For more information about this equipment and the Company, please visit www.lmark.net.

[Safety Instructions]

Please study the following before you begin to use this printer:

1. Safety warning



Warning: The print head generates heat. Do not touch it or other parts around it during printing or shortly after printing.



Warning: Do not touch the print head face or the connector; otherwise the print head may be damaged as a result of static.

Warning: This equipment is fitted with a cutting knife. Do not put your fingers near it during use. Be careful to keep clear of the cutting knife during handling.

2. Points of attention

- 1) The printer shall be put on a flat and stable place.
- 2) Do not use the printer or store it in hot, damp or heavily polluted places. Besides, keep it sheltered from sunshine, bright light and heat sources.
- 3) Do not put the printer in a place which is under the influence of vibration or impact.
- 4) Do not allow damp air condensate on the surface of the printer. If there is any condensate water, do not turn on the printer power supply before the condensate water disappears.
- 5) Connect the printer's power adaptor to a suitable earthed power socket. Avoid sharing a same power socket with other large dynamos or other equipment that may give rise to voltage fluctuation.
- 6) If the printer is expected to be idle for a long time, disconnect the printer from the power supply.
- 7) Be careful to avoid introducing water or conducting matters (like metals) into the printer. Disconnect the power supply immediately in case of such introduction.
- 8) Do not print if there is no print material loaded, otherwise the printer rubber roll and print head may be severely damaged.
- 9) Disconnect the power supply before making connection or disconnection; otherwise the printer control circuit may be damaged.
- 10) Do not attempt to dismantle the printer to repair by yourself. Unauthorized dismantling or alteration of this printer is prohibited, otherwise the high-voltage components inside may give rise to fire accident or electric shock.
- 11) For the benefit of safety, when the "protective cover" is opened the printer will not work. Therefore, put on the protective cover when printing. During opening the "protective cover", do not let any object touch the moving parts of the printer.
- 12) In order to avoid getting electric shock, do not plug or unplug any connections

- with a wet hand.
- 13) Do not use AC power supply exceeding 110V—240V in voltage.
 - 14) Keep the tube printer away from alcohol, gasoline and other volatile solvents; keep it away from fire to avoid explosion or burning.
 - 15) Clean the printer with a wrung wet cotton cloth. Use of organic and flammable solvent is prohibited.
 - 16) In case of strange odor or noises during operation, switch off the printer immediately and disconnect the power supply and then contact your sale agent.
 - 17) Stop the printer immediately if any foreign matter is introduced inside the printer in order to avoid damaging it.
 - 18) This printer prints only on sleeve tubes or heat shrink tubes with $\Phi \leq 6.0\text{mm}$. Printing on tubes $\Phi > 6.0\text{mm}$ may damage the printer.

[Caution]

1. Not all consumables are compatible with your machine. Compatibility is dependent on the features and specifications of consumables. Please use original **L-MARK** consumables, which ensure a steady printing quality and help protect your machine.
2. Use of non-original ribbon or label will invalidate the warranty.
3. Do not blockade the ribbon or label exit opening.
4. Do not strike the keyboard forcefully.
5. Do not pull out the print-out by force. Remove the print-out until it is cut off, otherwise the printing quality may be compromised or your machine may be damaged.
6. Consumables or machine shall be kept in a dry, room-temperature, and well ventilated place sheltered from direct sunshine.
7. This printer is designed so as to ensure a good printing quality on sleeve tubes, heat shrink tubes, labels, and transparent tubes; however no perfect quality for all types of printing is implied. Please print some trial samples in advance.
8. When printing PVC sleeve tubes, please use “tube guide” designed specially for this printer.

[Description of features]

- ◆ Full English operation interfaces, possible to enter English, numbers, symbols; various editing functions enabled;
- ◆ Ultra-large screen, three-line input and display; each line capable of showing 15 English letters;
- ◆ Fashionable and top-grade white background light LCD display, with status information of more than 10 functions displayed;
- ◆ Fully automatic semi-cutting or full-cutting operation;
- ◆ One-key operation: all functions can be performed by pressing only one key, thus offering a convenient and quick operation;
- ◆ International standard 85-key computer keyboard;
- ◆ Beautiful **L-MARK** font type, offering a clearer and more lasting print out;
- ◆ With a unique function of printing selected pages, enabling you to print selected pages in the current file;
- ◆ Ultra-large in-built file memory capacity, able to store more than 100 files, ready to be recalled at any time;
- ◆ **L-MARK** hi-speed computerized tube printer LK-330PC can be connected to a computer and **L-MARK** software offers new and versatile man-machine interfaces, compatible with Windows2000/XP operation systems; independent operation at the work site is possible, one machine designed for dual operations;
- ◆ Portable design, suitable to be used for various applications;
- ◆ Ribbons available in black, red, blue and white colors.

Chapter II Preparation

This chapter mainly describes the key components of the equipment and how to install the ribbons and printing materials. The function of each key is also described.

2.1 Configuration of the Main Unit

2.1.1 Basic configuration

1. LK-330E label and mark printer	1 piece
2. Warranty card	1 sheet
3. Packing list	1 sheet
4. Power adaptor (including power cable)	1 piece
5. Black ribbon for familiarizing purpose	1 cartridge
6. Sleeve tube guide	1 piece
7. Editing software and User's manual CD	1 CD
8. Computer connection cable	1 piece
9. Handbag	1 piece

2.1.2 List of consumables provided

species	specification	Model	Package
Labels	Label cassette tape (White 6mm)	LM506WL	5pcs(20m×5)/box
	Label cassette tape (White 9mm)	LM509WL	5pcs(20m×5)/box
	Label cassette tape (White 12mm)	LM512WL	5pcs(20m×5)/box
	Label cassette tape (Yellow 6mm)	LM506YL	5pcs(20m×5)/box
	Label cassette tape (Yellow 9mm)	LM509YL	5pcs(20m×5)/box
	Label cassette tape (Yellow 12mm)	LM512YL	5pcs(20m×5)/box
	Label cassette tape (Silver 6mm)	LM506SL	5pcs(20m×5)/box
	Label cassette tape (Silver 9mm)	LM509SL	5pcs(20m×5)/box
	Label cassette tape (Silver 12mm)	LM512SL	5pcs(20m×5)/box
Ink ribbons	Ribbon cassette (black)	LM33B	5pcs(80m×5)/box
	Ribbon cassette (white)	LM33W	5pcs(80m×5)/box
	Ribbon cassette (red)	LM33R	5pcs(80m×5)/box
Shrink tubes	2:1 heat shrink tube cassette (White 3.0mm)	LM-ST30W	5pcs(5m×5)/box
	2:1 heat shrink tube cassette (Yellow 3.0mm)	LM-ST30Y	5pcs(5m×5)/box
	2:1 heat shrink tube cassette (White 5.2mm)	LM-ST52W	5pcs(4m×5)/box
	2:1 heat shrink tube cassette (Yellow 5.2mm)	LM-ST52Y	5pcs(4m×5)/box
	2:1 heat shrink tube cassette (White 6.8mm)	LM-ST68W	5pcs(4m×5)/box
	2:1 heat shrink tube cassette (Yellow 6.8mm)	LM-ST68Y	5pcs(4m×5)/box
Cutter	Cutter (cutter holder and cutting blade)	LM-02-10	2pcs/box

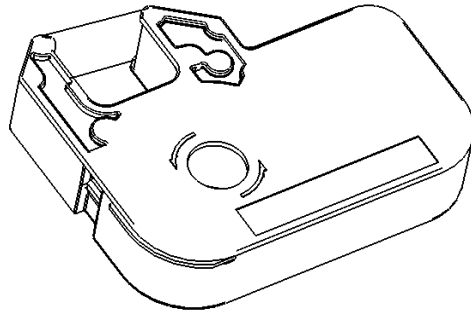

Ribbon

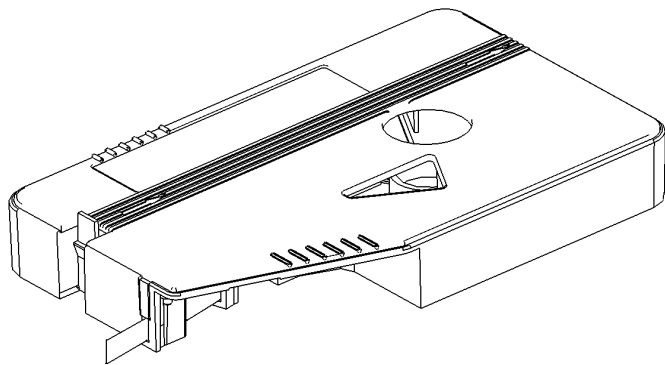

Label cassette/Heat shrink tube cassette

2.2 Nomenclature and Functions

2.2.1 Main unit

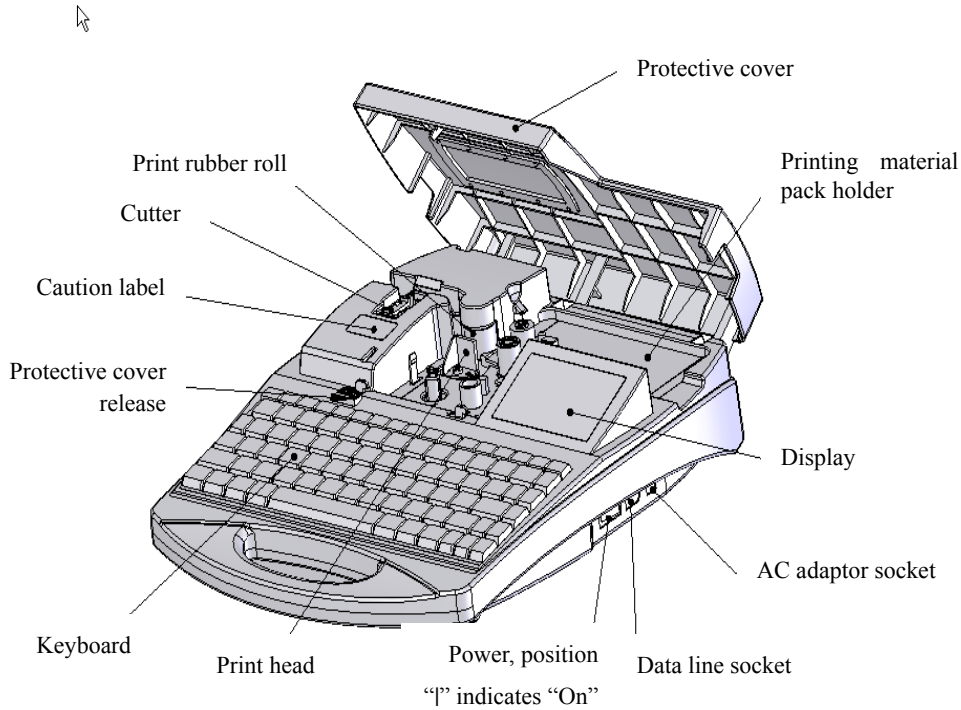

2.2.2 LCD display description

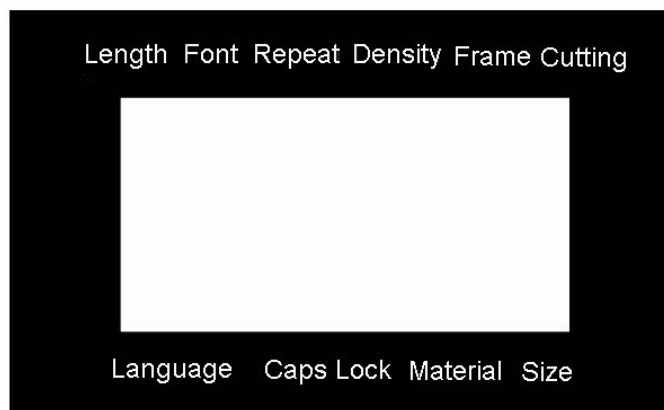

S/N	Display words	Interpretation
1	Length	Length of the page in which the cursor exists
2	Font	Font size of the page in which the cursor exists
3	Cutting	Status of semi-cutting function Y: semi-cutting L: demarcating N: Nil (no semi-cutting, no demarcating)
4	Frame	Effects setting of the page in which the cursor exists: N: Nil F: with frame L: underlined
5	Repeat	Repeated printing times of the page in which the cursor exists
6	Density	Value set for printing density
7	Caps Lock	Current status of upper case or lower case
8	Size	Size of printing medium
9	Material	Types of printing medium
10	Language	Current status of Chinese or English entry
11		Display contents: page number and page contents

2.2.3 Keyboard



[Medium] (page 30)

This key is used to selecting the print medium; available in label tape, PVC tube, and heat shrink tube

[Length] (page 30)

This key is used to change the length of the page

[A / >]—(Orientation) (page 32)

This key is used to change the printing orientation

[Font] (Font Size) (page 33)

This key is used to change character size

[Space] (Character Space) (page 34)

This key is used to change the spacing between character

[Density] (page 35)

This key is used to adjust printing density

[Frame] (page 35)

This key is used to put frame around the text or to underline it.

[Number] (Numbering) (page 36)

This key is used to set seril number input

[Repeat] (Repeat Printing) (page 38)

This key is used to set the repeated printing times of certain pages

[Alignment] (page 39)

This key is used to set the alignment of text, align left or center

[Double Line] (page 40)

This key is used to set double line

[PC Conn.] (PC Connecting) (page 41)

This key is used to connect to the computer and lock the keyboard.

[File] (page 41)

This key is used to register input data in the printer's memory. This key is also used to call up or delete registered data.

[Del All] (page 44)

This key is used to delete the file being edited

[Symbol] (page 44)

This key is used to electric symbol entry.

[Delete] (page 44)

This key is used to delete the page in which the cursor exists

[Cancel] (page 45)

This key is used to cancel the setting or operations, and return to the display to the previous screen.

[Superscript] (page 45)

This key is used to set superscript

[Subscript] (page 45)

This key is used to set subscript

[Text head] (page 46)

This key is used to move the cursor to the first page of the current document

[Text end] (page 46)

This key is used to move the cursor to the final page of the current document

[Print] (page 48)

This key is used to print the entire current document under edition

[Language] (page 48)

This key is used to choose language, available in En (English), Chinese (pinyin)

[Revise] (page 49)

This key is used to test and revise printing length, adjust the cutter and printer position.

[Shift] (page 49)

This key is used to in combination with the input keys to input upper-case character

[Caps Lock] (page 49)

This key is used to switch between upper-case input mode and lower-case input mode.

[Print Scope] (page 47)

This key is used to print selected pages in the text

[Cutting Set] (page 46)

This key is used to choose half-cutting, cut line, or wiyhout either half-cutting or cut line

[Cut Depth] (page 46)

This key is used to adjust the cutting depth of full-cut or half-cut

[Backspace] (page 49)

This key is used to delete the character that precedes the cursor

[Back Off] (page 48)

This key is used to remove the tube or the label tape.

2.3 Installation

2.3.1 Installation and removal of Ribbon

Installation of Ribbon

1. Open the protective cover
2. See the picture below; roll the ribbon tightly and neatly in the direction as shown.

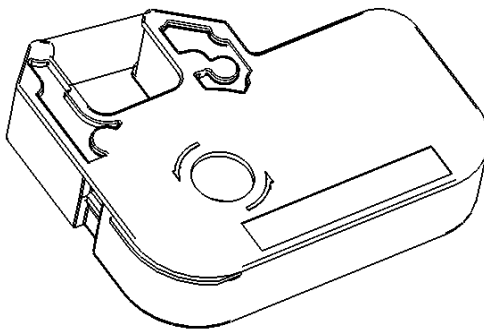

3. Place the Ribbon in the ribbon holder, as shown in the picture. You will hear a “crack” sound when it is properly located in its position.

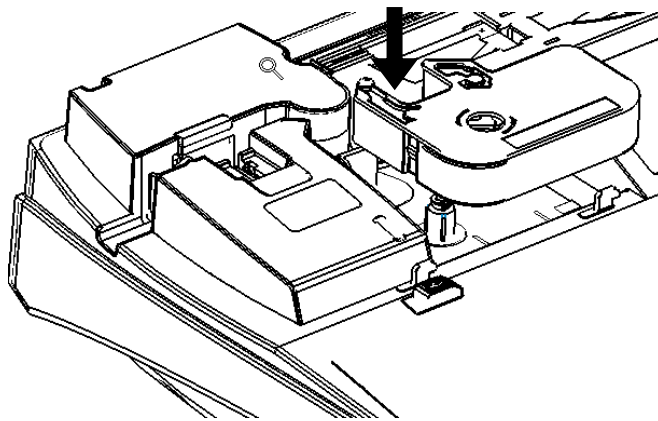

Installation of Ribbon

[Attention]

The Ribbon can not be detected by the printer if it is not properly installed. Therefore see that the Ribbon is placed into the correct place. If the Ribbon becomes loose, the machine may be unable to detect the Ribbon and the ribbon is prone to be torn broken or corrugated. So be sure to roll tight the ribbon prior to installation.

4. Close the protective cover

Removal of Ribbon

1. Open the protective cover

★ Make sure the print head is not pressed on the print rubber roll, in other words make sure the print head is released;

[Attention]

If the print head is found pressed upon the rubber roll, please close the protective cover and switch off the power and then switch on the printer about 3 seconds later. In this way, the printer will initialize anew and the print head will return to a proper place.

2. Raise the Ribbon and take it off carefully.

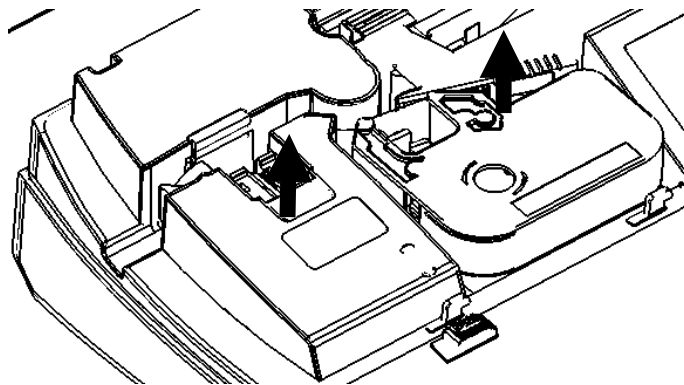

Removal of Ribbon

3. Remove the ribbon cassette when the catches on both sides are fully released.
4. Close the protective cover.

2.3.2 Installation and removal of printing material cassette

Installation of printing material cassette

1. Open the protective cover.
 - ◇ Be sure that the printer is already installed with an Ribbon.
2. Pull out 5-7mm long printing material from the cassette.

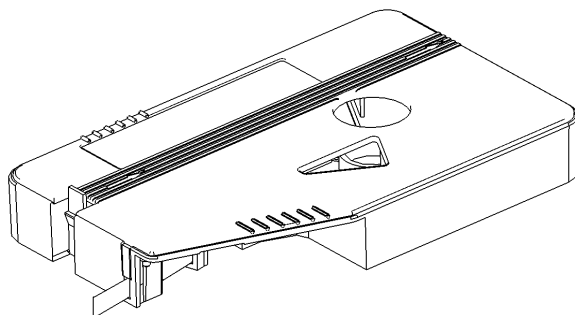

Label cassette

3. Put the tongue on the right side of the cassette into the trough on the cassette holder.
4. Press the cassette until you hear a “crack” sound, which indicates the cassette is installed in its place. Make sure the tongue has returned.

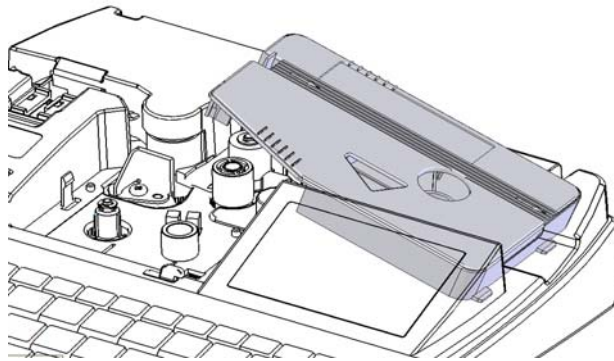

Installation of Label cassette

3. Close the protective cover

Removal of printing material cassette

1. Prior to removing printing material cassette, please press [Reverse] key and then press (Yes) and then press [Enter] key to roll back the printing material (cf. 4.2.27 [Reverse]).
2. Open the protective cover.
3. Press the left cassette tongue and at the same time raise the printing material cassette.
4. Pull out the tongue on the right side of the cassette from the trough on the cassette holder.

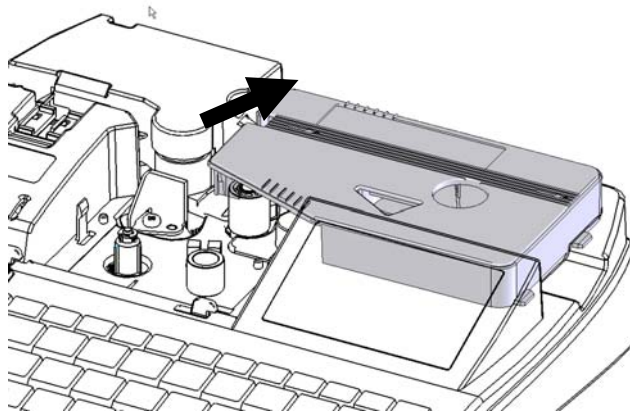

Removal of Printing Material cassette

5. Close the protective cover.

2.3.3 Installation of sleeve tube guide

1. Open the protective cover

- ◇ Make sure the printer is installed with an Ribbon.
- 2. Put the tongue on the right side of the guide into the trough of printing material cassette holder on the printer.
- 3. Press the guide until you hear a “crack” sound, which indicates the sleeve tube guide has been installed to its position. Make sure the tongue has returned.

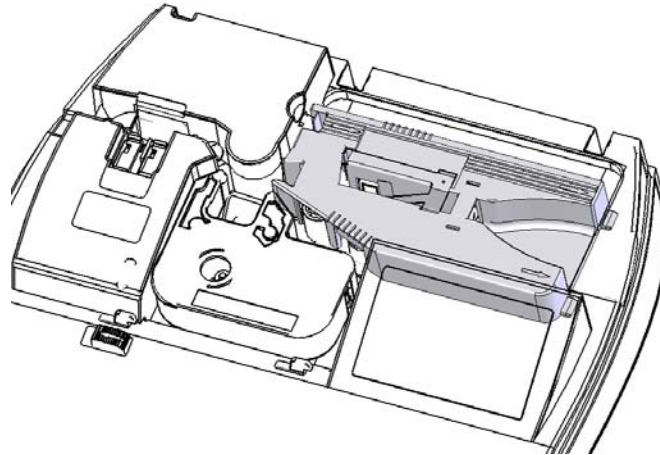

Installation of Sleeve Tube Guide

- 4. Close the protective cover

2.3.4 Installation of sleeve tube

- 1. Open the protective cover.
- ◇ Make sure that the Ribbon and sleeve tube guide have been properly installed.
- 2. Feed the sleeve tube from the feeding opening on the sleeve tube guide until its front end reaches the print rubber roll.

[Attention]

The sleeve tube to be fed shall be at least 30cm long.

Be sure to feed the front end of the sleeve tube that is soft or has an excessive deformation between the Ribbon and the print rubber roll.

See that the sleeve tube is properly fed. The pulling stress exerted by the machine shall not exceed 500G, otherwise the machine may not work properly.

- 3. Close the protective cover.

2.3.5 Removal of sleeve tube guide

The method is the same as that for the removal of printing material cassette.

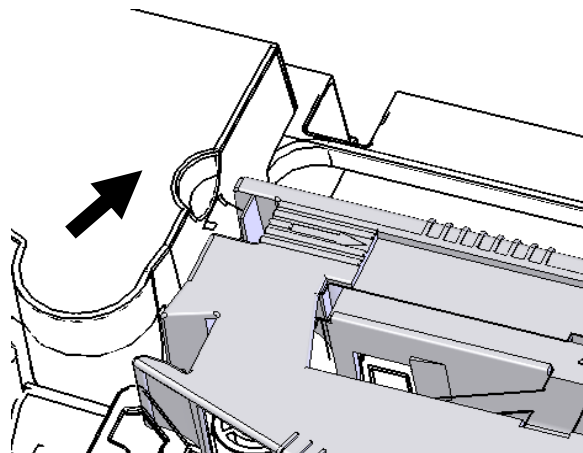

Removal of Sleeve Tube Guide

2.3.6 Connection of AC power adaptor

1. Switch off the power supply.
2. Plug one end of the AC power adaptor connection cable into the round socket on the side of the machine.
3. Plug the other end of the AC power adaptor connection cable into an AC power supply socket.

[Attention]

- Never plug AC power adaptor cable into data line socket.
- Do not connect AC power adaptor cable into power supplies other than rated voltage (100V to 240V), otherwise fire accident or electric shock may result.

2.3.7 Connection of data cable

1. Switch off the power supply.
2. Plug one end of the data cable into the data line socket on the side of the machine.
3. Plug the other end of the data cable into the serial port on the computer.

Switch on the power supply for use, and press **[PC Conn.]** key on the keyboard.

2.3.8 Power switch

Upon power on, the machine will emit a “De---” sound and the following power-on screen will be displayed. At this time, the cutter dynamo will initialize. Then, the machine will display the text edit window.

Note:

Do not switch on and off the machine repeatedly. Power on the machine several seconds after it is being switched off. Do not switch on the machine immediately after it is switched off, otherwise miss operation or data loss may result!



Automatic power off

To save power and to extend its service life, if the machine has been idle for 10 minutes while powered on without any operation, the automatic power off function will be performed. A machine in automatic power off mode has no response at all. To cancel this mode, switch off the power and power on again 3 seconds later.

[Attention]

A machine in automatic power off mode still consumes a little energy. Therefore, be sure to switch off the power supply if the machine is to be idle for a long time.

Replacement of the cutter

Take off the cutter to be replaced and install a new cutter.

Note:

- Be careful not to cut your finger when replacing cutter and anvil.
- If a new cutter does not produce the desired performance, please replace the anvil by appeal the sale agents.

Chapter III Basic Operation

Note:

In order to have a correct print out, please configure material options and specifications correctly and ensure that the tube printer configuration is compatible with your material and its specifications.

3.1 Power-on

Upon powered on, the machine will produce the following power-on display. At this time, the cutter dynamo will run and initialize.



3.1 Selection of Printing Material

After power-on display, the machine will produce material selection window and the screen will display as follows:

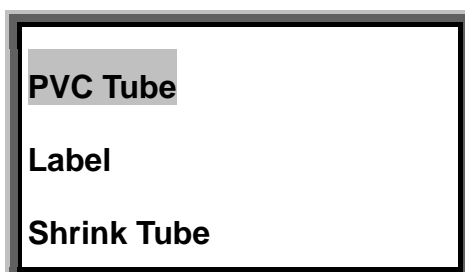

Use [←] or [→] keys to select the desired printing material, and then press [Enter] key.

3.2 Selection of Printing Material Specifications

3.2.1 Selection of sleeve tube specifications

Select "sleeve tube" on the material selection window and then press [Enter] key. The following window will be displayed:

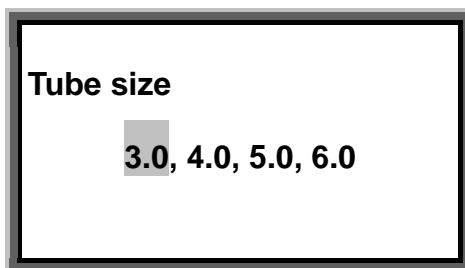

Use [←] or [→] keys to select the desired specification, and then press [Enter] key.

3.2.2 Selection of label specifications

Select “label” on the material selection window and press [Enter] key, then the following window will be displayed:

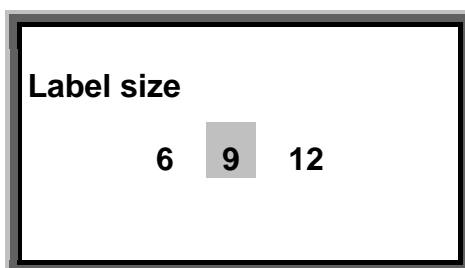

Use [←] or [→] keys to select the desired specification, and then press [Enter] key.

3.2.3 Selection of heat shrink tube specifications

Select “Shrink tube” on the material selection window and press [Enter] key, then the following window will be displayed:

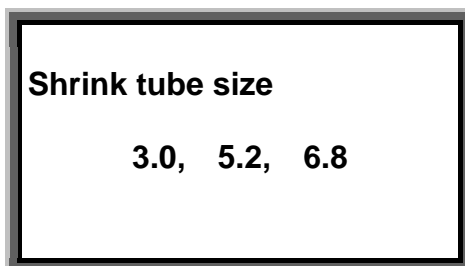

Use [←] or [→] keys to select the desired specification, and then press [Enter] key.

3.2.4 Selection of Font Size

After the selection of printing material specifications and press [Enter] key to recall the font size selection window. The screen will display as follows:

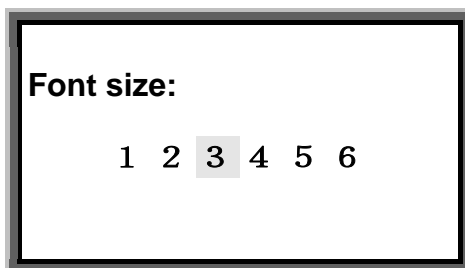

Use [←] or [→] keys to select the desired font size, and then press [Enter] key.

[Note]

- ▶▶ For 6mm label and 3.0 sleeve tube, you may choose font sizes 1, 2, 3,4;
- ▶▶ For 9mm label and 4.0 and 5.0 sleeve tube, you may choose font sizes 1, 2, 3, 4 and 5;
- ▶▶ For 12mm label and 6.0 sleeve tube, you may choose font sizes 1, 2, 3, 4, 5, and 6.

3.2.5 Change Character Size

After the selection of font size and press [Enter], The screen will display as follows:

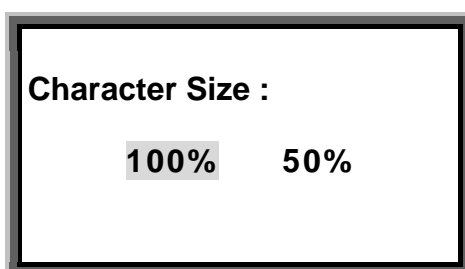

Use [←] or [→] keys to select the width font size, and then press [Enter] key to recall the edit window.

3.3 Enter Print Contents

After material and font size selection, you can enter into text editing window, in which you are allowed to input the print contents.

For example: to print the following contents in three pages:

L-MARK **AA1** **220V**

Select [Language], [Capital] as appropriate.

Enter L, -, M, A, R, and K one after another and the screen will display as follows:



Press [Enter] key, then another page is created automatically, and the screen will display as follows:



Enter A, A, and 1, and the screen will display as follows:

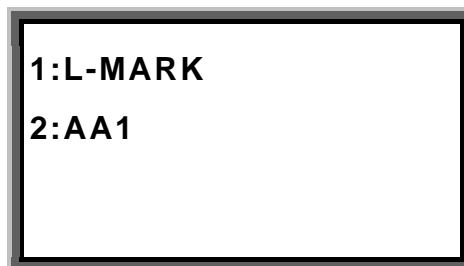

Press [Enter] key, and a new page is created automatically, and the screen will display as follows:

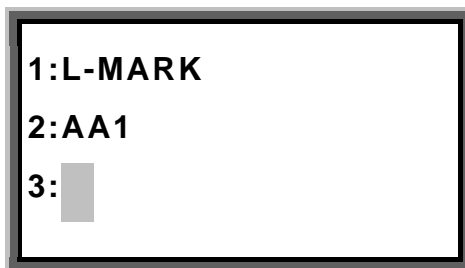

Input 2, 2, 0, and V one after another and the screen will be like this:



Press [Print] and the machine will print out the input contents and perform semi-cutting automatically. During printing, the LCD will display Printing.... When printing is completed, the machine will cut off the sleeve tube automatically and the text editing window will be displayed automatically. This round of operation has been completed.

3.4 Insertion

If you need to insert another page in the already edited contents, you may use [↓] or [↑] keys to move the cursor behind the page behind which you want the new page to be inserted. Then, press [Enter] and another empty page will be created. And then input the contents you want.

For instance: to insert 50A behind L-MARK in the above example, move the cursor behind the first page and press [Enter]. A new blank page will be created and the previous second page becomes the third page.

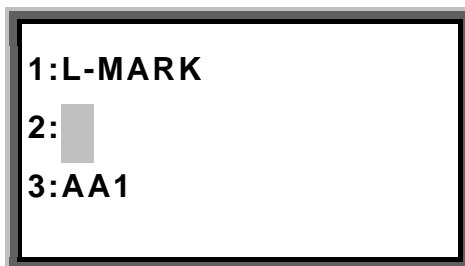

Input 5, 0, and A one after another in the second page and the screen will display as follows. This insertion operation is thus completed.

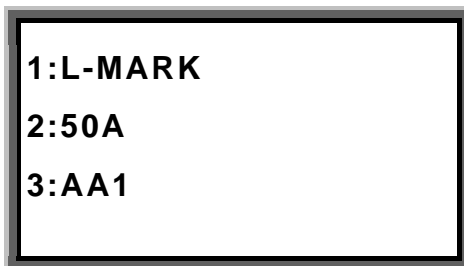

3.5 Change of Contents

If you want to make changes to the text, you may use [↓] or [↑] keys to move the cursor to the page where you desire to make changes, and use [←] or [→] keys to move the cursor behind the characters which you want to change. Then use “Backspace” key to delete the characters and then input new characters you want.

Chapter IV Function Keys

4.1 Notes to Function Keys

1. [] indicates a function key and framed contents indicate screen display.
2. A miss operation will result in a piece of error information on the screen. Miss operations can not be performed.
3. Function keys not yet used retain their original factory setting.
4. In printing mode, none of the function keys will work.
5. While you are editing a function key, the rest function keys can only be used when this function key has completed its editing task or the editing status has been Reversed (only [Cancel] key can be used to exit from an editing status).
6. After you complete editing function keys, you will see the text editing window.
7. A new page shares the same attributes with the preceding page.
8. The five settings, namely length, font size, repeat, effects, and direction are all related to the cursor location. After you have completed the setting, the page in which the cursor exists and all the pages behind it will have the same settings. You may use [Text head], [Text end], [↓], [↑], [→] and [←] keys to move the cursor.
9. The screen can display up to 3 lines, each line being able to display up to 12 English letters or 8 Chinese characters.
10. The contents of each page are displayed in one line (in bi-page settings, the contents behind the bi-page symbol are in the second line), therefore if the screen can not display a long page, the previous input contents will be shifted to the left on the screen.
11. Length, font size, semi-cutting, effects, repeat, color strength, upper & lower case, material type, Chinese or English, page number, and page contents setting status are all displayed on the screen.
12. For bi-line, the line distance is constant; for bi-columns, the column distance is constant.
13. The initial setting of letter keys is UPPER CASE.

4.2 Instructions for Function Keys

4.2.1 Medium

You may choose label, PVC sleeve tube, or heat shrink tube as the material to be printed on.

Be sure to select the correct material before printing; after replacing the printing material, be sure to change the settings of the tube printer so that they are compatible with the new printing material; otherwise it may compromise the printing quality, result in printing error or damage the print head.

Press [Material] key, and the screen display will be as follows:

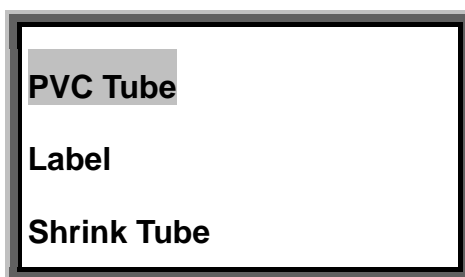

Press [→] or [←] to choose or , and press [Enter]. Then a window will be displayed to select the specific material specifications. Press [→] or [←] to select the desired specification and press [Enter], then you will enter into the text editing window.

Press [→] or [←] to choose , and press [Enter], then you will enter into the text editing window.

Note:

- After selecting the printing material, if you choose a font size that is too large for the material, the screen will display as below:

4.2.2 Length

Specified page length and automatic page length are valid for the page in which the cursor exists and for all the pages behind it. Overall length adjustment is valid for all the pages in the document.

This function is provided to specify the page length to be printed. The length ranges from 6mm to 100mm, and shall be integer numbers only.

Press [Length] key, and the screen will display as follows:



▶▶ Specified page length

Select Specify Length, press [Enter] key, and the screen will display as follows:

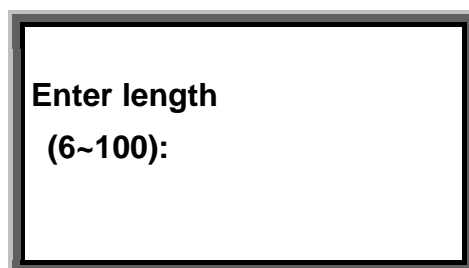

Input the page length value you desired at the cursor and then press [Enter]. The page in which the cursor exists and all the pages behind it will assume this specified length. Then the screen will show the text editing window automatically.

For example: Enter "18", the page length will be 18mm.

Note:

- If the selected page length is too short to print out all the characters, a message will be prompted: Page contents too long! Press any key to return!
- For specified page length, if the input characters are too many, a message will be prompted: Page contents too long! Press any key to return!

▶▶ Automatic page length

This function will generate a page length automatically depending on the letters, symbols, character spacing, and font size.

Select Automatic length, and press [Enter], then the page in which the cursor exists and all the pages behind it will assume an automatic length. Then, the screen will show the text editing window automatically.

After you set an automatic font size, if you select Automatic length and press [Enter], the following message will be shown:

Font size is auto, can't set auto length. Any key to return!

4.2.3 [A/➤] Orientation

This function is provided to set the printing orientation. The initial setting is horizontal printing.

Press [A/➤] key and then the page in which the cursor exists and all the pages behind it will be printed in horizontal or vertical orientation as appropriate.

You are advised to make this setting before you enter the contents. Otherwise, it may display Page contents too long! message.

Press [A/◀] key, and the screen will display:

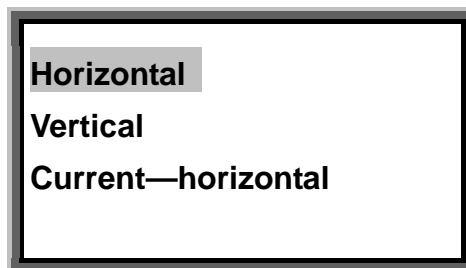

Press [↑] or [↓] to select and the press [Enter], then the page in which the cursor exists and all the pages behind it will be printed in the orientation you selected. Then, the screen will return to the text editing window automatically.

Note:

- Reverting from horizontal to vertical printing may result in incorrect print out; this depends on character number, font size, and font setting. If the contents are

too long for printing after reverting from horizontal to vertical orientation, the screen will display the following message:

Page contents too long! Press Cancel to return.

4.2.4 Font size

This function is provided to set font size.

The setting of font size is valid for the page in which the cursor exists and all the pages behind it.

Press [Font size] key and the screen will display as follows:



Press [↑] or [↓] to select and press [Enter].

- ▶▶ Select **Specify font size** and press [Enter], then the screen will display as follows:



Move the cursor to the font size you desire and press [Enter], then the page in which the cursor exists and all the pages behind it will assume the font size you choose. The screen will return to the text editing window automatically.

- ▶▶ **Automatic font size**

This function is provided to enable the machine to adjust the font size and character spacing so as to ensure valid entries and ensure a same material length when no page length has been specified.

Note:

- After you have chosen automatic page length function, automatic font size function will become invalidated. After you have chosen automatic page length function, if you attempt to set font size and press [Enter], then the following message will be displayed:

Page length too long! Press [Cancel] to return.

4.2.5 Spacing

This function is provided to set the spacing between characters.

This setting is valid for all the contents to be printed.

Press [Spacing] and the screen will display as follows:

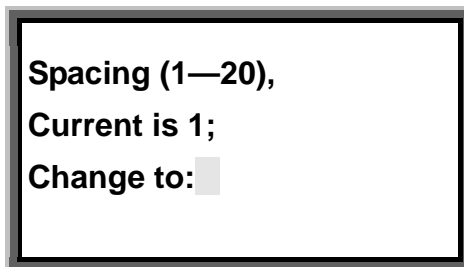

Enter the value you want and press [Enter], and then the screen will return to the text editing window automatically.

Note:

- If the spacing is too large, the screen will display **Exceeds the limits! Adjustment is invalid!**
- The spacing is 1—20 in an ascending order.

4.2.6 Density

This function is provided to set the printing density.

This setting is valid for all the contents to be printed.

Press [Density] key and the screen will display as follows:

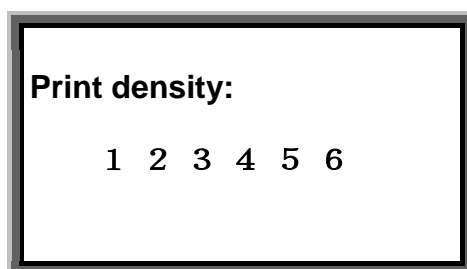

Press [→] or [←] to select the desired value and press [Enter], then the setting is completed and the screen will return to the text editing window automatically. 1, 2, 3, 4, 5, 6 have an ascending print color strength.

Please select the print color strength according to the ambient temperature: in summer when the temperature is high, please select a lower strength value.

4.2.7 Frame

This function is provided to add frame or underline to certain pages. The initial setting does not have any effects.

When this setting is on, the page in which the cursor exists and all the pages behind it will share the same effects.

Press [Frame] and the screen will display as follows

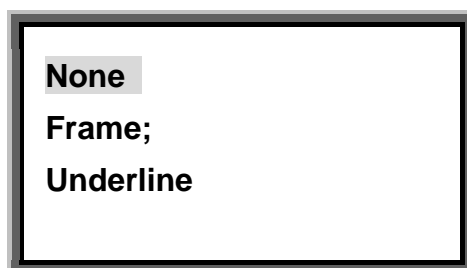

▶▶ None

Select None and press [Enter], then the page in which the cursor exists and all the pages behind it will have no effects.

▶▶ To add effects

Press [↑] or [↓] to select Frame or Underline and press [Enter], then the page in which the cursor exists and all the pages behind it will be framed or underlined. Then, the screen will return to the text editing window automatically.

Note:

- The screen will display “F” for Frame effects and “L” for Underline effects;
- For bi-line (horizontal), the framed contents when printed out is like:

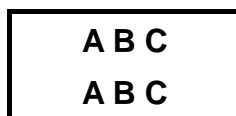

- For bi-line (vertical), the framed contents when printed out is like:

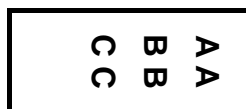

4.2.8 Number

This function is provided to generate sequential page contents according to the input numbers or letters and according to certain patterns. Decimal system is used for serial number. One page can only have one serial number in order to be printed.

Serial number printing function is available for any place in a page.

Move the cursor to a place in a page desired and press [Number] key, then the screen will display as follows:

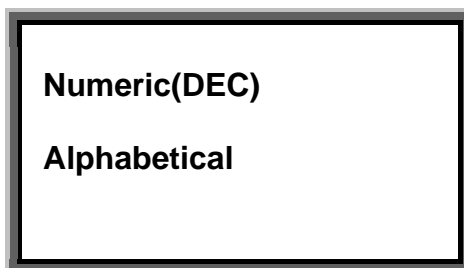

▶▶ Numerical serial number

Select and press [Enter], then the screen will display as follows:

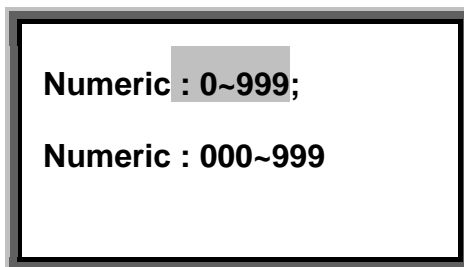

Serial number format: 0~999 indicates natural serial number, like 0, 1, 2, ..., 999;

Serial number format: 000~999 indicated aligned serial number, like 001, 002, ..., 999.

Press [↑] or [↓] to select your desired choice and press [Enter], then the screen will display as follows:

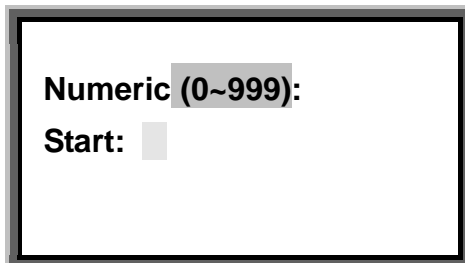

A rectangular screen with a double border. The text 'Numeric (0~999):' is at the top, with '0~999' highlighted in grey. Below it, 'Start:' is followed by a small grey square.

Input the starting serial number and press [Enter], then the screen will display as follows:

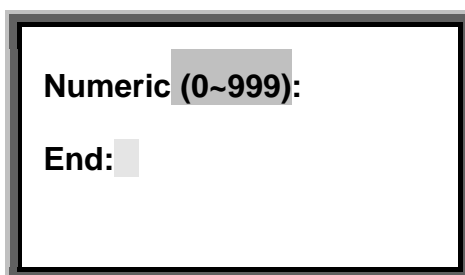

A rectangular screen with a double border. The text 'Numeric (0~999):' is at the top, with '0~999' highlighted in grey. Below it, 'End:' is followed by a small grey square.

Input the terminating serial number and press [Enter], then the setting is completed and the screen will return to the text editing window automatically.

Then, the text editing window will display serial number status as below:

For natural serial number (0—999): 

For aligned serial number (000—999): 

▶▶ Letter sequence

Select Alphabetical and press [Enter], then the screen will display as follows:

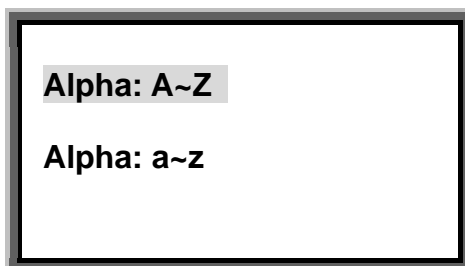

A rectangular screen with a double border. The text 'Alpha: A~Z' is at the top, with 'A~Z' highlighted in grey. Below it, 'Alpha: a~z' is displayed.

Press [↑] or [↓] to select your desired choice and press [Enter], then the screen will display as follows:

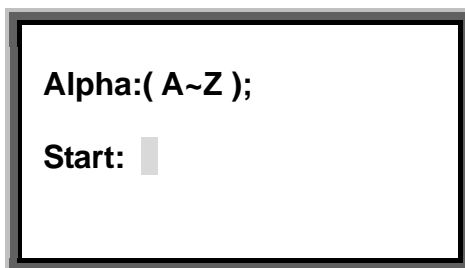

Enter the starting sequential letter and press [Enter], then the screen will display as follows:

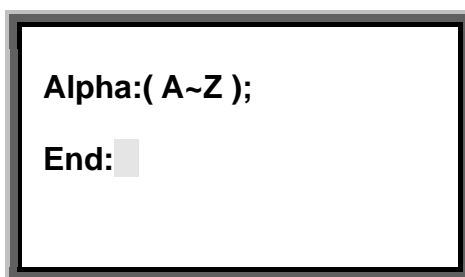

Enter the terminating letter and press [Enter], the setting is completed and then the screen will return to the text editing window automatically.

Now, the text editing window will display the following sequential letter status:

For UPPER CASE sequential letter (A—Z): **A**

For lower case sequential letter (a—z): **a**

Note:

- If a page has been assigned both an S/N and a Repeat function, then the S/N function will be executed before Repeat.
- The numbering function can not used in the vertical print mode.

4.2.9 Repeat

This function is provided to set the repeated printing times of certain pages. The repeated times can be any one from 1 to 20. The initial setting has a repeat number of 1, which means the selected contents will be printed only once.

Once this command is used, the page in which the cursor exists and all

the pages behind it will have the same repeated printing times.

Press [Repeat], then the screen will display as follows:

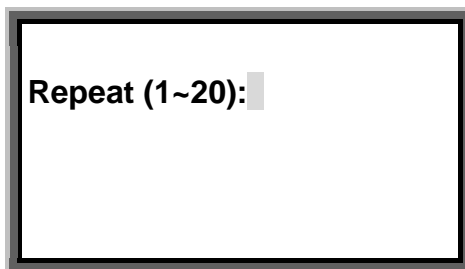

Enter the number (integer) you want to repeat and press [Enter], and the page in which the cursor exists and all the pages behind it will be printed repeatedly for the number of times you just input, and then the screen will return to the text editing window automatically.

If the input number exceeds the limits or is not an integer, the screen will display Exceeds the limits, Press any key to enter another number! Now press any key to input a valid integer.

4.2.10 Alignment

This function is used to set the left alignment or center alignment of the characters.

This setting is valid for all the contents to be printed.

Press [Alignment] and then the screen will display as follows:

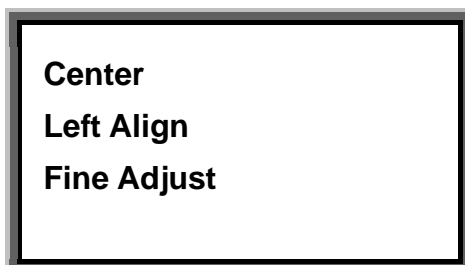

Press[↑] or [↓] to make your selection.

1. Select Center and press [Enter], then the contents will be printed in a center alignment manner. The screen will return to the text editing window automatically.
2. Select Left alignment and press [Enter], then the contents will be printed in a left alignment manner. The screen will return to the text editing window automatically.
3. To select Fine adjustment, just select it and press [Enter].

Fine adjustment is used to fine adjust the print contents toward the left or the right when the print contents can not be aligned center or left completely as previously

envisaged due to material or other external factors.

The initial setting is Center and there is no fine adjustment.

- If you have selectd the tube after you press [Enter], then the screen will display as follows:

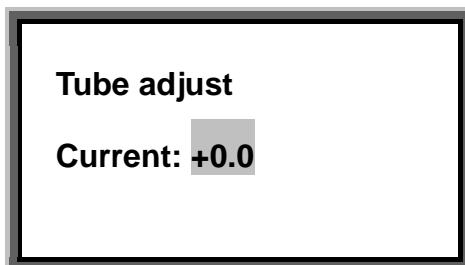

Press [Enter], then the screen will display as follows:

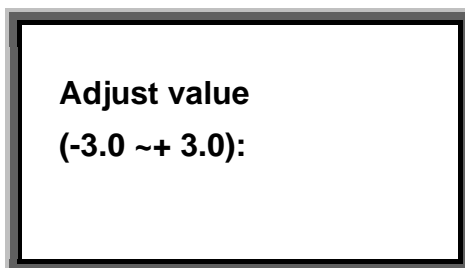

The fine adjustment ranges from -3.0 to +3.0mm.

- If you have selectd the label after you press [Enter], then the screen will display as follows:

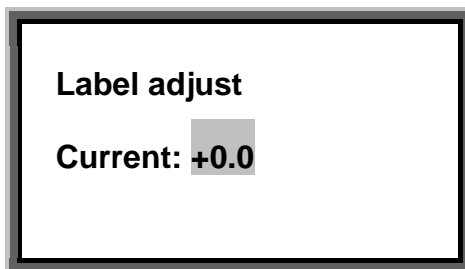

Press [Enter], then the screen will display as follows:

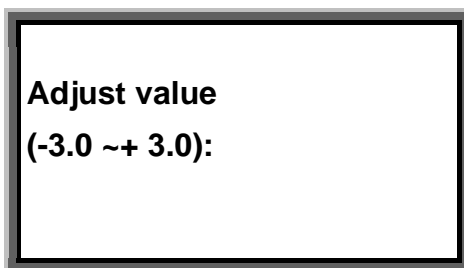

For example: if you want to shift the print contents leftward by 2.7mm, you can input 2.7; if you want to shift the print contents rightward by 2.7mm, you can input -2.7; then press [Enter], and the screen will return to the text editing window.

4.2.11 Double Line

This function is provided to enter 2 lines of characters in one page. The initial setting is 1 line.

Move the cursor behind a place in the page where you want to start a new line and press [Line number], then the bi-line symbol  will be shown. The contents behind this symbol will be printed in a new line.

Note:

- To print 6mm labels, if bi-line is chosen, you can only use font size 1 and 2;
- To print 9mm and 12mm labels, if bi-line is chosen, you can only use font size 1, 2, and 3;
- You can only have 2 lines or 2 columns at the most;

4.2.12 PC Conn.

This function is provided to connect a computer and lock the keyboard. Pressed [**PC Conn.**] then the screen will display as follows:

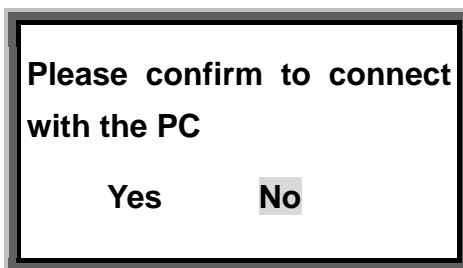

Press [→] or [←] to select the “Yes” or “No” and press [Enter]. If select “Yes” and pressed [Enter] then the screen will display as follows:



4.2.13 File

Use this function you can save all the input contents as a files in the machine’s internal memory. To save it as a file, you need to give it a mane. You can open or delete saved files.

Press [File] and the screen will display as follows:



» Save file

Select **Save file** and press [Enter], then the screen will be displayed as follows:



input your file name (10 characters at the most).

A: If the name you input exists or the current file has already been saved, then the screen will display a message as below:

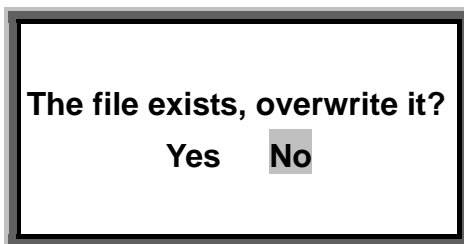

You may overwrite the existing file or save as another file.

B: If the name you input does not exist, the file will be saved straightaway and the screen will return to the text editing window.

Note:

- The main unit of this machine is able to save 100 files.

▶ **Open File**

Select and press [Enter].

A: If no file exists, the screen will display as follows:

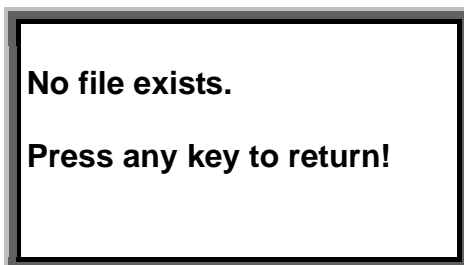

B: If there is (are) file(s), the screen will display the name(s) of the saved file(s).

Select the name you want and press [Enter], the screen will then display as follows:

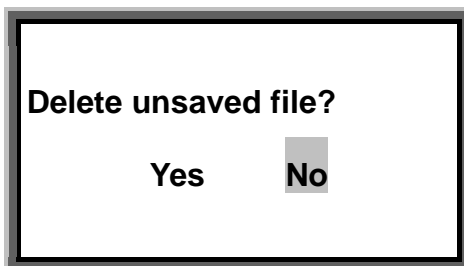

Select “Yes”, then the current file will be deleted and the accessed file will be opened.

» **Delete file**

Select **Delete file** and press [Enter], then the screen will display as follows:



A: Delete one by one

Press[↑] or [↓] to select **Delete one file** and press [Enter].

If no file exists, then the screen will display as follows:

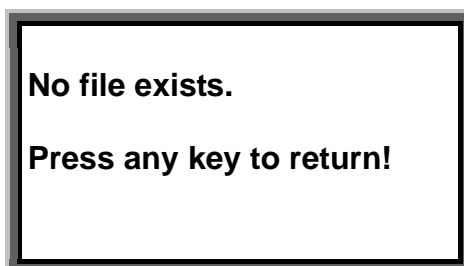

If there is (are) file(s), please select the file you want to delete, then the screen will display as follows:

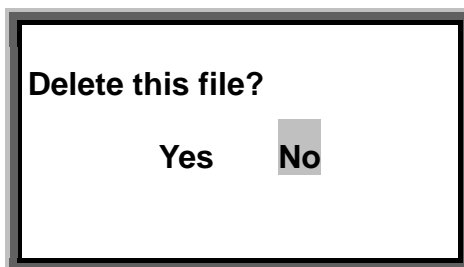

Select "Yes" and press [Enter], then this file is deleted. Then, the screen will return to the text editing window.

B: Delete all the files

Select **Delete all files**, and select "Yes" and press [Enter], then all the saved files will be deleted and the screen will return to the text editing window.

4.2.14 Delete all

This function is provided to delete all the pages input and to create a new file.

Press “Delete all”, then the screen will display as follows:

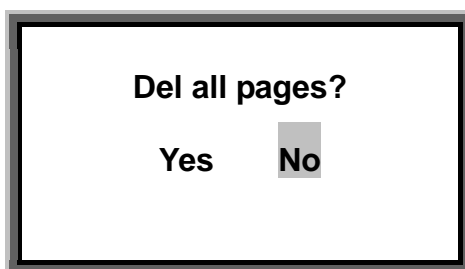

Select Yes and press [Enter], then all the input pages will be deleted, and the cursor will return to the initial input location and a new file is created.

Select No and press [Enter], then no contents will be deleted and the window will return to the previous editing window.

Note:

- Deleted contents can not be recovered.

4.2.15 Symbol

- This key is used to select the electric symbol. Press[<] or [>] to select the page and press the decimal number to select the symbol you need.

4.2.16 Delete

This function is provided to delete the page in which the cursor exists.

Move the cursor to the page you want to delete and press [Delete], then the screen will display as follows:

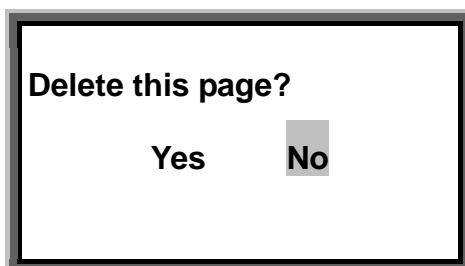

Select Yes to delete this page.

A deleted page can not be recovered. The other pages will be renumbered.

4.2.17 Cancel

To cancel the setting or operation in progress or to cancel incorrect statement, to return to the menu of immediately superior level or to return to text entry interface

4.2.18 Superscript

Move the cursor behind the character where you want to input superscript and press [Superscript], then a superscript symbol  appears behind this character.

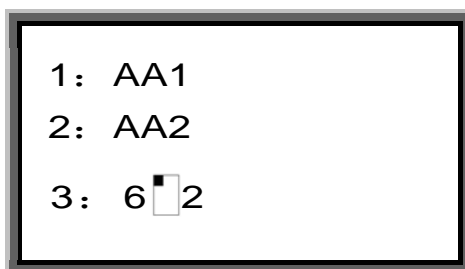

Then enter the superscript character. For instance: to put superscript 2 behind the number 6, then the print-out will be 6².

4.2.19 Subscript

Move the cursor behind the character where you want to input subscript and press [Subscript], then a subscript symbol  appears behind this character.

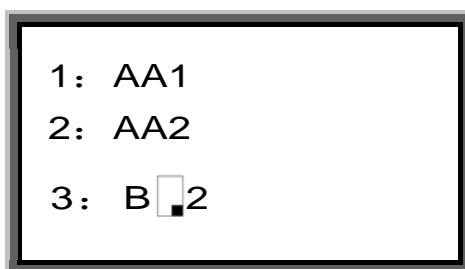

Then enter the subscript character. For instance: to put superscript 2 behind the letter B, then the print-out will be B₂.

Note:

- Press the superscript or subscript key will only generate one superscript or subscript character. To have more than one superscript or subscript character, you

need to press the superscript or subscript key repeatedly.

4.2.20 Text head

This function is provided to move the cursor to the first page of the current document.

4.2.21 Text end

This function is provided to move the cursor to the final page of the current document.

4.2.22 Cutting set

This setting is valid for all the contents to be printed.

This key is provided to set half-cut, cutting line(no half-cutting), and nil (no half-cutting, no cutting line). The initial setting is half-cutting.

Press [Cutting setting] and the screen will display as follows:

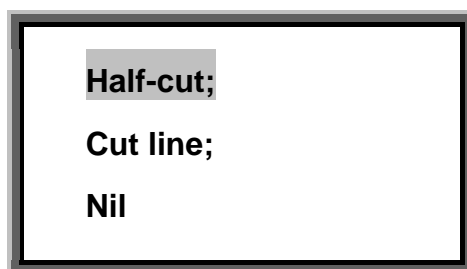

Press [↑] or [↓] to make your selection and press [Enter] to complete the setting. Then, the screen will return to the text editing window automatically.

4.2.22 Cut depth

The initial setting value for half-cut depth is "0".

- If you have selected the tube after press [**half-cut depth**] and the screen will display as follows:

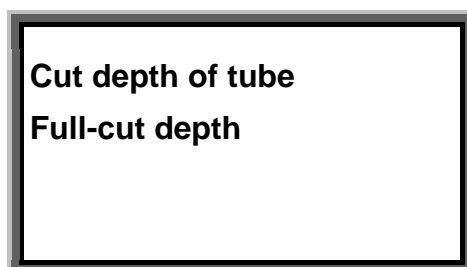

▶▶ **Adjust half-cut depth of tube**

Select and press [Enter], then the screen will display as follows:

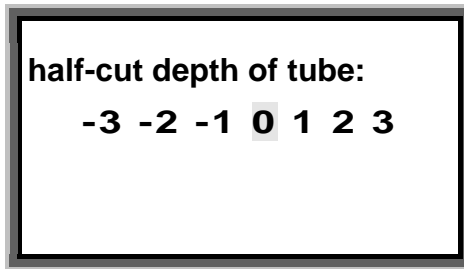

Use [→] or [←] to make your selection and press [Enter] to finish sleeve tube semi-cutting depth. Cutting depth ascends from -3 to +3.

If you have chosen a semi-depth of +3 but are not satisfactory with the semi-cutting results, then you may need to replace your cutter assembly.

▶▶ **Adjust full-cut depth**

Select and press [Enter] to finish your full cutting depth setting.

The cutting depth ascends from -3 to +3.

- If you have selected the label after press [half-cut depth] and the screen will display as follows:

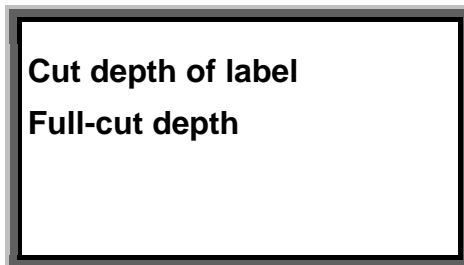

▶▶ **Adjust half-cut depth of label**

Select and press [Enter] to finish your label semi-cutting depth.

The cutting depth ascends from -3 to +3.

If you have chosen a semi-depth of +3 but are not satisfactory with the semi-cutting results, then you may need to replace your cutter assembly.

▶▶ **Adjust full-cut depth**

Select and press [Enter] to finish your full cutting depth setting.

The cutting depth ascends from -3 to +3.

4.2.23 Print Scope

This function is provided to print selected pages in the text.

This setting allows you to print the pages selected by you (blank pages will not be printed).

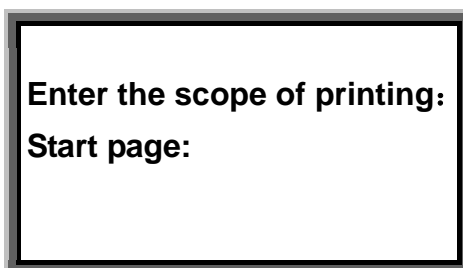

When you have finished the ending page number for printing and press [Enter], the machine will begin to print.

If you do not enter the starting page number, then the default value will be the number of the page in which the cursor exists; if you do not enter the ending page number, then the number of the last page will be the default value. That is to say, if you do not input the starting page number nor the ending page number, then the machine will print the page in which the cursor exists until the last page of this document.

4.2.24 Print

After you have made all the settings and input the print contents, this function enables you to print the contents of all the pages in the current document on the printing material.

Blank pages will not be printed.

During printing, the screen will display Printing.

4.2.25 Capital

Press this button once to alternate between upper case and lower case input (invalid for Chinese input). The initial setting is English upper case.

4.2.26 Language

This key is used to shift among different language. Now the machine can use English and Chinese. The initial setting is English upper case input.

Press [language] to select and current entry status will be displayed on the left lower corner on the screen. **[CH]** indicates Chinese pinyin entry method; **[En]** indicates English entry method;

4.2.27 Back Off

This key is used to reverse the rubber roll to take off the label or tube. Due to material difference or miss operation, the printing material may be jammed on the rubber roll.

Press this key to reverse the roll and help remove the jammed material.

Press [Back off] key and the screen will display as follows:

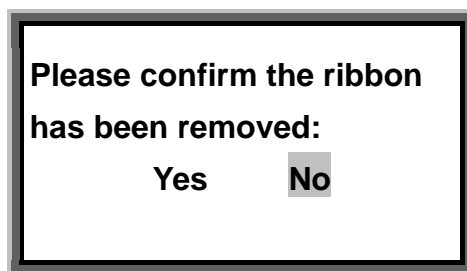

Select **[Yes]** and press [Enter], then the rubber roll will be reversed. This operation can be repeated until the jammed material is taken out.

Note:

- Before Reverse operation, be sure that the print head is released and the color ribbon is removed.

4.2.28 Backspace

This function is provided to delete the character before the cursor.

Move the cursor behind the character you want to delete and press [Backspace], and then the character before the cursor will be deleted.

Pressing [Backspace] continuously will delete all the characters in the page; however the page number will not be deleted. The blank page will not be printed.

To delete a page, please use [Delete] key.

Note:

- Deleted characters can not be recovered.

4.2.29 [Shift]

Shift key.

4.2.30 Revise

This function is provided to test and correct printing length. And this function is provided to adjustment the position of the printerhead and cutter.

- **Due to ambient temperature variance or material difference by different manufactures, the actual printed page length may be a little different from what you have specified.**

If you find a large discrepancy between the actual printed page length with what you have specified, this function helps you to adjust so that the printed length coincide with the specified length.

- When you print label or flat heat shrink tube you may want print in the center of vertical. You can use function to do it.
- Sometime when you select auto-length but the page can not be placed in the middle of two cutter line, you can use this function to adjust the position of cutter line.

Under the tube medium

Press [Revise] and the screen will display as follows:



Choose Tube Length, make sure the tube is loaded properly, and press [Enter] to start printing; Then, you may inspect the printing effect of your tube printer.

▶▶ **Cutter Adjustment**

Choose , then sent -2.0~+5.0 can to adjust the position of cutter line.

Under the Label medium

Press [Revise] and the screen will display as follows:

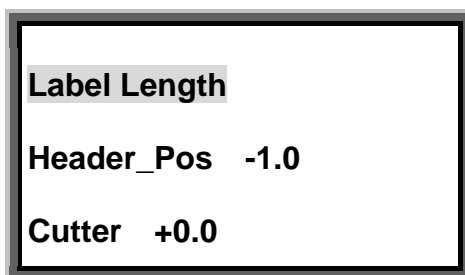

▶▶ **Length Adjustment**

Choose , make sure the label is loaded properly, and press [Enter] to start printing;

When completing printing, the machine will display as follows:

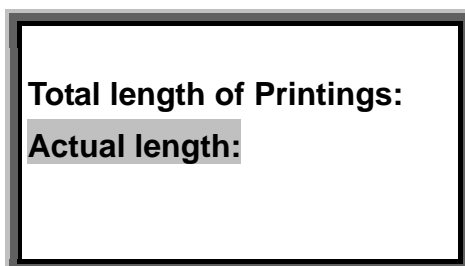

Then, you may inspect the printing effect of your tube printer.

For example:

If the measured total length of these four printings is 101.5mm, you just enter “101.5” and then press [Enter].

With this function, it is possible to adjust the actually printed length to what you have specified.

▶▶ **Printerhead position Adjustment**

Choose and the screen will display as follows:

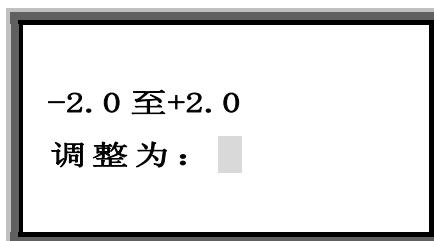

Then sent -2.0~+2.0 can to adjust the position of printer head.

For example:

Now the printer head position is -1.0. If input “0.2” the printer head position will move upwards 0.2mm. The position is -0.8mm.

▶▶ **Cutter position Adjustment**

Choose and the screen will display as follows:

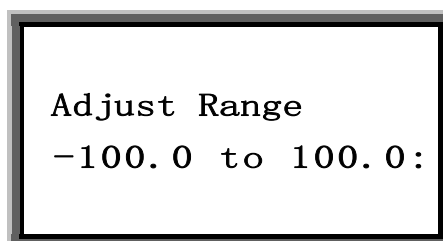

Then sent -100.0~+100.0 can to adjust the position of cutter. The unitage 1=0.0847mm.

For example:

If input -10 the cutter line position will move 0.847mm to left.

▶▶ **Length Adjustment**

When completing printing, the machine will display as follows:

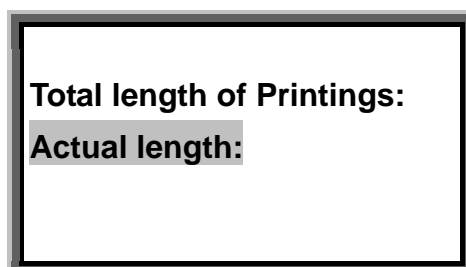

For example:

If the measured total length of these four printings is 101.5mm, you just enter “101.5”

and then press [Enter].

With this function, it is possible to adjust the actually printed length to what you have specified.

4.2.31 Create a new page

This function is provided to insert a new page between two existing pages or append it to the end of the text.

▶▶ **Create a new page at the end of the text.**

Move the cursor to the last page of the text and press [Enter], and then you have just created a new page at the end of the text.

▶▶ **Insert a new page between two pages**

Move the cursor to a page and press [Enter], then you have just created a new page behind the said page.

Note:

- The new page assumes the same attributes with its preceding page.
- The new page assumes a page number sequentially.
- If the new page contains nothing, it will be ignored during printing.

4.2.32 Display brightness adjustment

Keep [Ctrl] pressed and press [→], [←], [↑], or [↓] key to adjust the screen brightness or contrast.

4.2.33 Key combination

▶▶ **[Ctrl] + [Shift] + [Y]**

Used to see the type of the ribbon.

▶▶ **[Ctrl] + [Shift] + [V]**

Used to see the Version number of the software.

▶▶ **[Ctrl] + [Shift] + [L]**

Used to see the length of the ribbon.

Chapter V Specifications Description

Model	LK-330
Mode of printing	Thermal transfer printing
Resolution	300dpi
Printing character height	1.3mm—8mm
Maximum number of input pages	198
Sleeve tube size printable	Φ2.5—Φ6
label size printable	6mm、9mm、12mm
Printing speed	11.5mm/sec(with half-cut)
Display	LCD, white color background, displaying up to 5 lines
Characters	Chinese, English, number,symble
Entry method	standard 85-key
Memory	About 100,000 characters
Material cutting method	Automatic half-cutting, automatic full-cutting
Power supply	DC 12V 2A
Ambient requirements	Operation: Temp 15°C~35°C Relative humidity 10%~85% (without condensation) Storage: Temp 5°C~35°C Relative humidity 10%~85% (without condensation)
Overall	350(L)*290(W)*95(H)
Weight	About 3kg

[Attention]

Due to product update, the specifications are subject to change without prior notifications.

Chapter VI Others

6.1 Specifications of Original Consumables

species	specification	Model	Package
Labels	Label cassette tape (White 6mm)	LM506WL	5pcs(20m×5)/box
	Label cassette tape (White 9mm)	LM509WL	5pcs(20m×5)/box
	Label cassette tape (White 12mm)	LM512WL	5pcs(20m×5)/box
	Label cassette tape (Yellow 6mm)	LM506YL	5pcs(20m×5)/box
	Label cassette tape (Yellow 9mm)	LM509YL	5pcs(20m×5)/box
	Label cassette tape (Yellow 12mm)	LM512YL	5pcs(20m×5)/box
	Label cassette tape (Silver 6mm)	LM506SL	5pcs(20m×5)/box
	Label cassette tape (Silver 9mm)	LM509SL	5pcs(20m×5)/box
	Label cassette tape (Silver 12mm)	LM512SL	5pcs(20m×5)/box
Ink ribbons	Ribbon cassette (black)	LM33B	5pcs(80m×5)/box
	Ribbon cassette (white)	LM33W	5pcs(80m×5)/box
	Ribbon cassette (red)	LM33R	5pcs(80m×5)/box
Shrink tubes	2:1 heat shrink tube cassette (White 3.0mm)	LM-ST30W	5pcs(5m×5)/box
	2:1 heat shrink tube cassette (Yellow 3.0mm)	LM-ST30Y	5pcs(5m×5)/box
	2:1 heat shrink tube cassette (White 5.2mm)	LM-ST52W	5pcs(4m×5)/box
	2:1 heat shrink tube cassette (Yellow 5.2mm)	LM-ST52Y	5pcs(4m×5)/box
	2:1 heat shrink tube cassette (White 6.8mm)	LM-ST68W	5pcs(4m×5)/box
	2:1 heat shrink tube cassette (Yellow 6.8mm)	LM-ST68Y	5pcs(4m×5)/box
Cutter	Cutter (cutter holder and cutting blade)	LM-02-10	2pcs/box

[Attention]

This machine can only use original ink ribbons supplied by its manufacturer. It may not be able to print with all the printing materials available at the market. For more information, please contact your nearest sale agent.

6.2 Simple Trouble-shooting

Problem	Cause	Solution
Text is not center aligned after semi-cutting	Material difference	Please use "Fine adjustment" to adjust the text alignment.
Actual page length differs from the specified value	Material difference	Please use "Correct" function.
Poor semi-cutting quality	Semi-cutting blade has been worn out	Please replace the semi-cutting blade
On-line printing operation is not responding	Driver software not installed	Please install driver software
	The main unit is not in text editing window	Please enter into text editing window on the main unit.
Printing not clear	Sleeve tube is too hard; Stained sleeve tube surface	Please clean the tube or use an acceptable tube.
	Ink ribbon crimped	Take out the ribbon or tidy it up, or replace it by a new one.
	Print head worn out or scratched	Change the print head
	Material configuration not matching	Please change material configuration to ensure it agrees with the materials used.
	Ambient temperature too low or too high	Please adjust the print color strength or change the ambient temperature.
Incomplete printing characters	Font size too large	Use a smaller font size.
	Material specifications not properly set	On the machine, please set the material specifications to be compatible with the materials used.
	Print head worn out or scratched	Change the print head
The machine is printing, but there is not print out	Print head connection line is improperly connected	Please connect the print head connection line properly
	Print head damaged	Change the print head
	Semi-cutting not deep enough	Please adjust the semi-cutting depth
label sticks to the blade	Semi-cutting depth is too large	Please select a smaller semi-cutting depth
	The cutting edge is glued	Please clear the cutting edge of glue.
Ink ribbon slanted and curled in edges	Problem with sleeve tube guide	Please replace the sleeve tube guide.
	Problem with ink ribbon	Please replace the ink ribbon.

6.2 Warranty Card

L-MARK®

Product Warranty Card

I. Notes to Product Warranty

1. This card and the invoice for the machine are the evidence for product warranty service. This card and the invoice shall be posted to us when warranty service is demanded.
2. The Company provides two-year charge-free warranty service (3-month for print head) calculated from the date of purchase.
3. This card will be not re-issued or replaced when it is lost or tampered with, please keep it in good custody.

II. Any of the following circumstances will invalidate this warranty service

1. The warranty period of the machine or components has expired.
2. Malfunctions or damages as a result of improper installation, operation, and maintenance not conforming to this manual or as a result of operation in an ambience other than that required by this manual.
3. Malfunctions or damages as a result of maintenance, alteration or dismantling by organizations or personnel not authorized by the Company.
4. Malfunctions or damages as a result of using components other than original ones specific to the machine.
5. Malfunctions or damages caused by falling, crushing, water inundation, dampness or other human errors.
6. Malfunctions or damages as a result of force majeure (war, earthquake, and flood, etc.).
7. All consumables (like ink ribbon and label paper, etc.) are not covered under this warranty.
8. Product model has been tampered with or becomes illegible.

III. Points of Attention

1. To avoid the delayed service due to incomplete documents, please make ready your warranty card and purchase invoice when requesting for service. If the warranty or purchase invoice cannot be provided, the Company will provide service based on the manufacture date. If no warranty evidence can be provided, the Company will provide warranty service based on the manufacture date retrieved from your product serial number; if no valid information is retrieved, the Company reserves the right not to provide charge-free warranty service.
2. Products serviced by the organization authorized by the Company are still covered by the original warranty commitments. Should the balance of the warranty period after such service is less than three months, the components serviced will be covered by a 3-month warranty calculated from the date in which they have been repaired. You will be requested to show the service record in due time for this 3-month warranty service.
3. Within the warranty period, the Company is entitled to the ownership of the parts or components replaced.

L-MARK®

Product Warranty Card

Product information S/N:

Model		Product S/N	
-------	--	-------------	--

Client information:

Name			
Address			
Contact		Tel.	
Fax		Postal code	
E-mail			

Service record:

Date	Cause and reparation of faults	Repaired by

Sale agent:

--

Manufacturer: LABEL & MARK INDUSTRIES COMPANY

<http://www.lmark.net>

Manufacturer: LABEL & MARK INDUSTRIES COMPANY
<http://www.lmark.net>

Printed in china